

COPPER RETROFIT ROOF DRAINS

RETROFIT DRAINS

ProSeal™



“The Name Says It All!”

FEATURES

- *Heavy Duty, Durable, Long Lasting Copper*
- *Also available in Spun Aluminum*
- *Strong Mechanical Seal Prevents Water Backups*
- *Large 3 Bolt Strainer Dome*
- *All Common Sizes Available*
- *Bolt Down Clamping Ring for Single-Ply Systems*
- *Variable Length Copper Outlets, Up to 15"*

BEFORE COMPRESSION

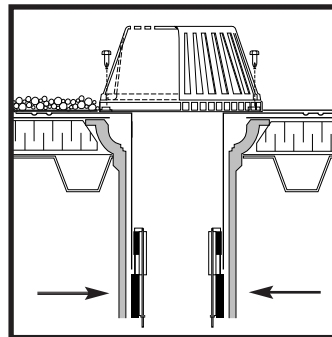

AFTER COMPRESSION

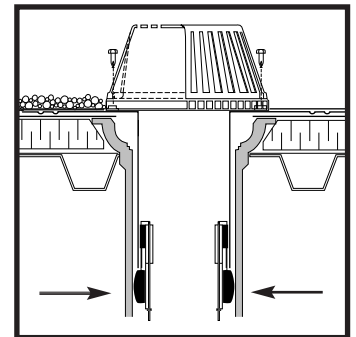

**Marathon**
Roofing Products
3310 N. Benzing Road, Orchard Park, NY 14127-1538
PH: (716) 332-7673 • FAX: (716) 332-7676

FOR MORE INFORMATION:
CALL TOLL-FREE 1-800-828-8424
Website: www.marathondrains.com • E-mail: mrp@marathondrains.com

SPECIFICATIONS

ADVANTAGES

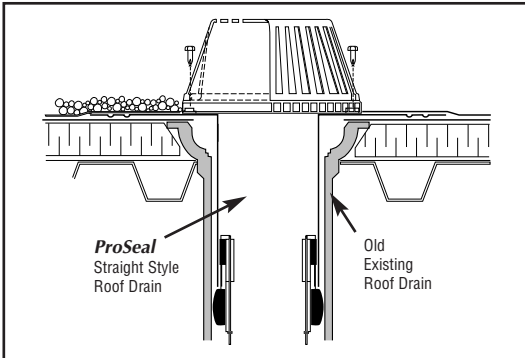

- A Copper Drain with mechanical seal
- Also available in spun aluminum
- Compression of mechanical seal eliminates water backing up into roof system
- Fits all standard sizes of existing roof drains
- Installs from the rooftop using simple hand or power screwdriver with square head adapter
- Offered in variable length outlets, up to 15"
- Proven performance of both copper, aluminum drain and mechanical seal
- Economical to purchase and simple to install

INSTRUCTIONS

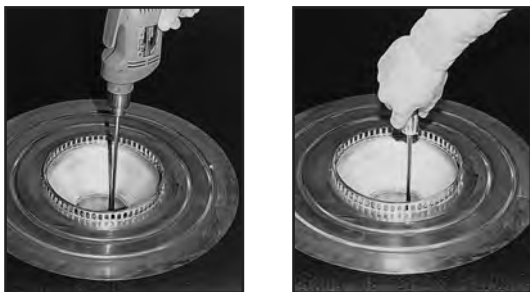

See website for installation instructions - www.marathondrains.com

ProSeal Installation Drivers: Drivers have special non-slip square heads to adapt to ProSeal expansion screws. Power shaft easily installs in any power drill for fast expansion of drain seal.

TYPE	SIZE		LENGTH
STRAIGHT (STR)	EXISTING DRAIN SIZE (A) inches/mm	OUTSIDE DIAMETER (B) inches/mm	STRAIGHT (C) inches/mm
ProSeal (STR) 3	3" 76 mm	2.8" 72 mm	11" 279 mm
ProSeal (STR) 4	4" 102 mm	3.78" 96 mm	11" 279 mm
ProSeal (STR) 5	5" 127 mm	4.70" 119 mm	11" 279 mm
ProSeal (STR) 6	6" 152 mm	5.65" 144 mm	11" 279 mm

Standard: **ProSeal** drains include 10" (203mm) high density polyethylene (black Plastic) strainer dome

Options for **ProSeal** Drains:

- CR clamping ring for straight styles only
- drain outlets may be ordered extended by 6" (152 mm)
- cast iron stainer dome
- flange coatings: Asphalt, PVC or Plain (standard)



Quality Products for Professional Roofers