



RD-200-CP
Tag: _____

Roof Drain w/ 8" x 8" Promenade Top

SPECIFICATION: Drainage RD-200-CP epoxy coated cast iron promenade roof drain with flashing clamp with integral gravel stop, 8"x8" (203x203) square epoxy coated ductile iron promenade top, and no hub (standard) outlet.

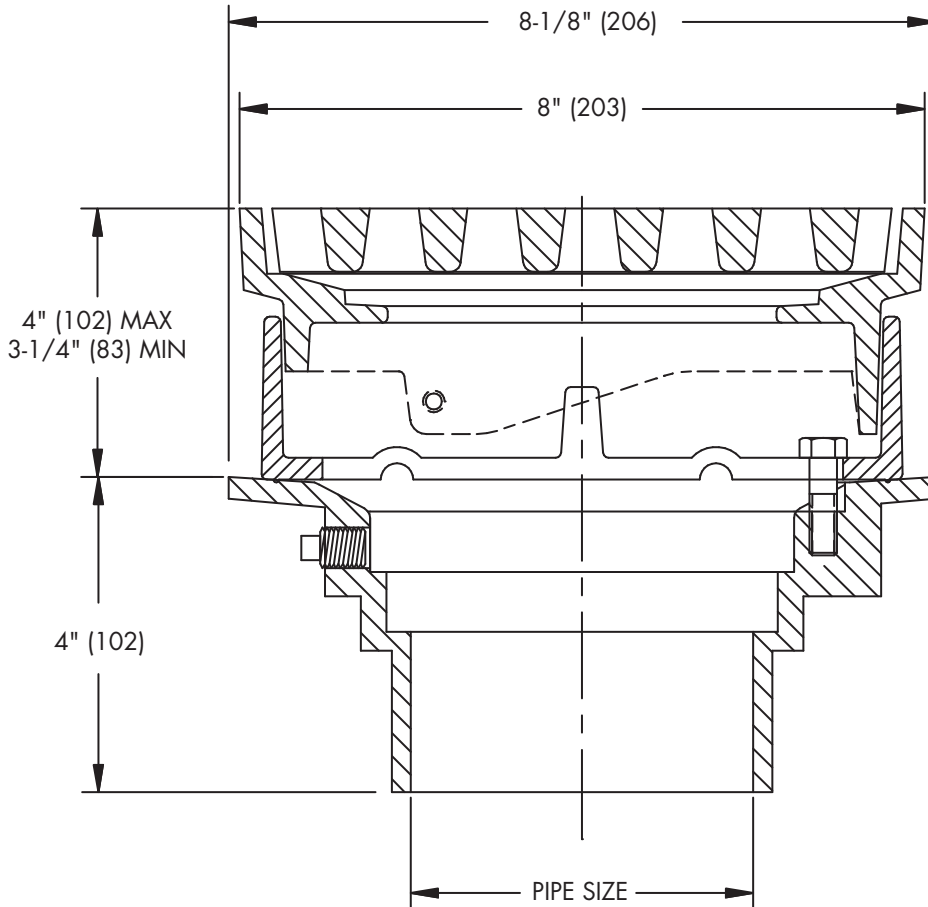

Chart B

	Std.	P	T	X	60/61
Pipe Size	No Hub	Push On	Female Thread	Inside Caulk	PVC/ABS
2"(51)	3-5/8"(92)	4-1/4"(108)	4-1/4"(108)	4-1/4"(108)	3-3/4"(95)
3"(76)	3-5/8"(92)	4-1/4"(108)	4-1/4"(108)	4-1/4"(108)	3-5/8"(92)
4"(102)	3-5/8"(92)	4-1/4"(108)	4-1/4"(108)	4-1/4"(108)	3-7/8"(94)

Load Rating & Free Area

Suffix	Load Rating	Free Area Sq. In.
CP	*HD	15

* The load classifications are in accordance with the American National Standards ASME A112.21.1M ASME Ratings are as follows:
HD - Safe Live Load 5000-7499 lbs. (2250-3375kg)
The above categories are given as a guide only. Please consult factory.

Components



Pipe Sizing (Select One)

Suffix	Description	
2	2"(51) Pipe Size	<input type="checkbox"/>
3	3"(76) Pipe Size	<input type="checkbox"/>
4	4"(102) Pipe Size	<input type="checkbox"/>

Outlet Type (Select One)

Suffix	Description	
NH	No Hub (MJ)	<input type="checkbox"/>
P	Push On	<input type="checkbox"/>
T	Threaded Outlet	<input type="checkbox"/>
X	Inside Caulk	<input type="checkbox"/>

Options (Select One or More)

Suffix	Description	
-1	All Nickel Bronze Top	<input type="checkbox"/>
-6	Vandal Proof Top	<input type="checkbox"/>
-9	Hinged Grate	<input type="checkbox"/>
-12	Galvanized Top	<input type="checkbox"/>
-13	Galvanized Body & Flashing Clamp	<input type="checkbox"/>
-B	Sump Receiver	<input type="checkbox"/>
-D	Underdeck Clamp*	<input type="checkbox"/>
-F	Adjustable Extension Flange	<input type="checkbox"/>
-SO	Side Outlet	<input type="checkbox"/>
-US	Buy American Compliant	<input type="checkbox"/>

Optional Body Material

Suffix	Description	
-60	PVC Body w/Socket Outlet	<input type="checkbox"/>
-61	ABS Body w/Socket Outlet	<input type="checkbox"/>

Job Name _____ Contractor _____

Job Location _____ Contractor's P.O. No. _____

Engineer _____ Representative _____

Marathon Roofing Products reserves the right to modify or change product design or construction without prior notice and without incurring any obligation to make similar changes and modifications to products previously or subsequently sold. See your Marathon representative for any clarification. Dimensions are subject to manufacturing tolerances.



3310 N. BENZING ROAD • ORCHARD PARK, NY 14127-1538 • PH: (716) 332-7673 • FX: (716) 332-7676
TOLL-FREE: 800-828-8424 • EMAIL: MRP@MARATHONDRAINS.COM • WEB: WWW.MARATHONDRAINS.COM