



RD-700

Tag: _____

Dual Outlet Roof Drain/Overflow

SPECIFICATION: Drainage RD-700 epoxy coated cast iron dual outlet roof drain/overflow combination with flashing clamp, integral gravel stop, 4"(102) high internal overflow standpipe, secured ductile iron dome, and no hub outlets.

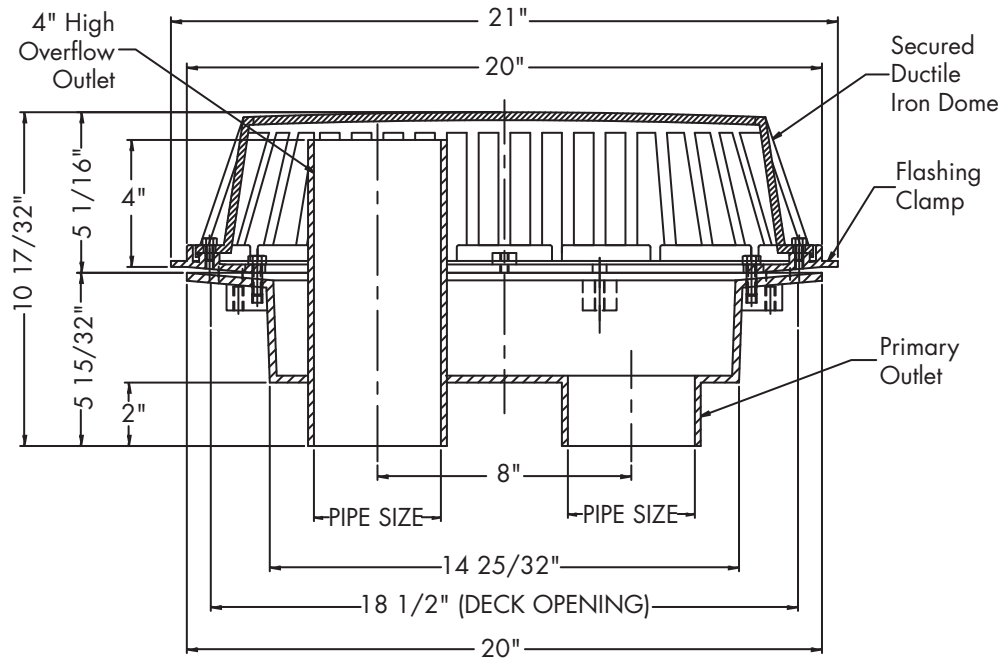

Pipe Sizing (Select One)		
Suffix	Description	
3	3"(76) Pipe Size	<input type="checkbox"/>
4	4"(102) Pipe Size	<input type="checkbox"/>
6	6"(152) Pipe Size	<input type="checkbox"/>

Options (Select One or More)		
Suffix	Description	
-B	Sump Receiver	<input type="checkbox"/>
-D	Underdeck Clamp	<input type="checkbox"/>
-F	Adjustable Extension Flange	<input type="checkbox"/>
-L	Vandal Proof Dome	<input type="checkbox"/>
-W2	2" High Overflow	<input type="checkbox"/>
-13	Galvanized Body and Clamp	<input type="checkbox"/>

Deck Opening:
 18-1/2"(470) x 10-1/2"(267)
with Sump Receiver:
 22"(559) x 14"(356)

Free Area Sq. In.
157

Job Name _____ Contractor _____

Job Location _____ Contractor's P.O. No. _____

Engineer _____ Representative _____

Marathon Roofing Products reserves the right to modify or change product design or construction without prior notice and without incurring any obligation to make similar changes and modifications to products previously or subsequently sold. See your Marathon representative for any clarification. Dimensions are subject to manufacturing tolerances.



3310 N. BENZING ROAD • ORCHARD PARK, NY 14127-1538 • PH: (716) 332-7673 • FX: (716) 332-7676
 TOLL-FREE: 800-828-8424 • EMAIL: MRP@MARATHONDRAINS.COM • WEB: WWW.MARATHONDRAINS.COM